

NOCCHI VARIO 3-20

THREE-PHASE PRESSURE BOOSTER SET WITH TWO VARIABLE SPEED PUMPS

EASY TO INSTALL, LOW POWER CONSUMPTION, VERSATILE OPERATION

The new series of variable speed pressurization booster set VARIO3-20 represents a reliable solution which is easy to use, for residential and industrial applications. The systems involves the installation of two pumps in parallel featuring electronic control. VARIO3 is an electronic device capable of changing the frequency of a pump. Integrated directly on the motor, it allows to adjust its speed so as to supply the same pressure at all times, even when the water demand changes. When the system pressure drops below the set threshold, the module starts the first pump of the unit to restore to set-point pressure; the speed of rotation of the pump varies according to the water demand so, a greater demand will correspond to a higher speed, until the

maximum speed set has been reached, after which, if the system requires greater performance, the module will activate the second pump to keep the pressure stable. As the water demand decreases, the speed of the last pump started is reduced, until it turns off. The module will keep the first pump on until the minimum set speed has been reached, after which, if there are no further pressure drops, the pump will be stopped. VARIO3-20 features five operating modes to meet the operating needs.



TECHNICAL FEATURES

- Inverter supply voltage: 3x380-500 Vac
- Inverter output voltage: 3x380-500 Vac
- Maximum output power: up to 2x11 kW
- Input frequency: 50/60 Hz
- Output maximum rated power: up to 20 Amp
- Degree of protection: IP55
- Max. ambient temperature: + 50°C
- Input filter complying with EMC directive
- Pressure transducer: 0-5 Volt 0-10 bar
- Connectivity: Serial interface RS 485
- Optional contacts: 3 (external set-point, alarm, system inhibition)

BASE

- in galvanized metal complete with rubber isolated pads

SUCTION MANIFOLD

- in stainless steel AISI 304 with 2 ball valves

DELIVERY MANIFOLD

- In stainless steel AISI 304 with:
 - n. 2 ball valves
 - n. 2 check valves
 - n. 1 pressure gauge
 - n. 2 pressure sensors

USAGE DATA	MULTINOX VE+			PVM						
	4	6	8	1	3	5	10	15	20	32
Maximum capacity (m ³ /h)	10,8	16,8	25,2	4,8	9	17	26	47	58	80
Maximum head (m.c.a.)	140	110	140	16	16	160	160	165	145	120
Maximum operating pressure	12 bar	16 bar	16 bar	16 bar						
Power supply VOLT	3-400 V									
Ambient temperature	50° C									
Degree of protection of pump	IP55									
Degree of protection of electrical panel	IP54									

NOCCHI VARIO 3-20

THREE-PHASE PRESSURE BOOSTER SET WITH TWO VARIABLE SPEED PUMPS

CONTROL PANEL

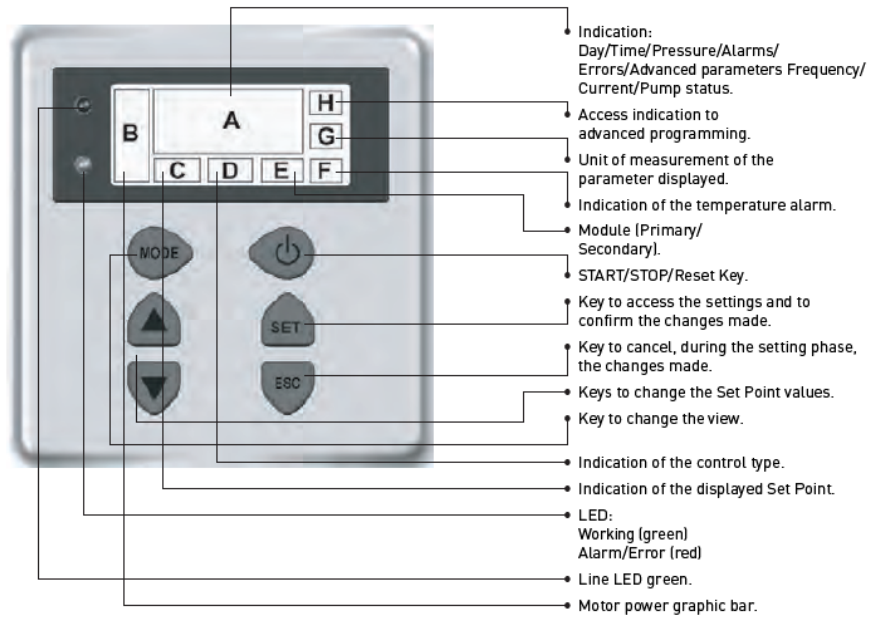

- Backlight display (switches off automatically after a reset time and can be turned on again by pressing any key)

NOCCHI VARIO 3-20 PVM

THREE-PHASE PRESSURE BOOSTER SET WITH TWO VARIABLE SPEED PUMPS

HYDRAULIC PERFORMANCE

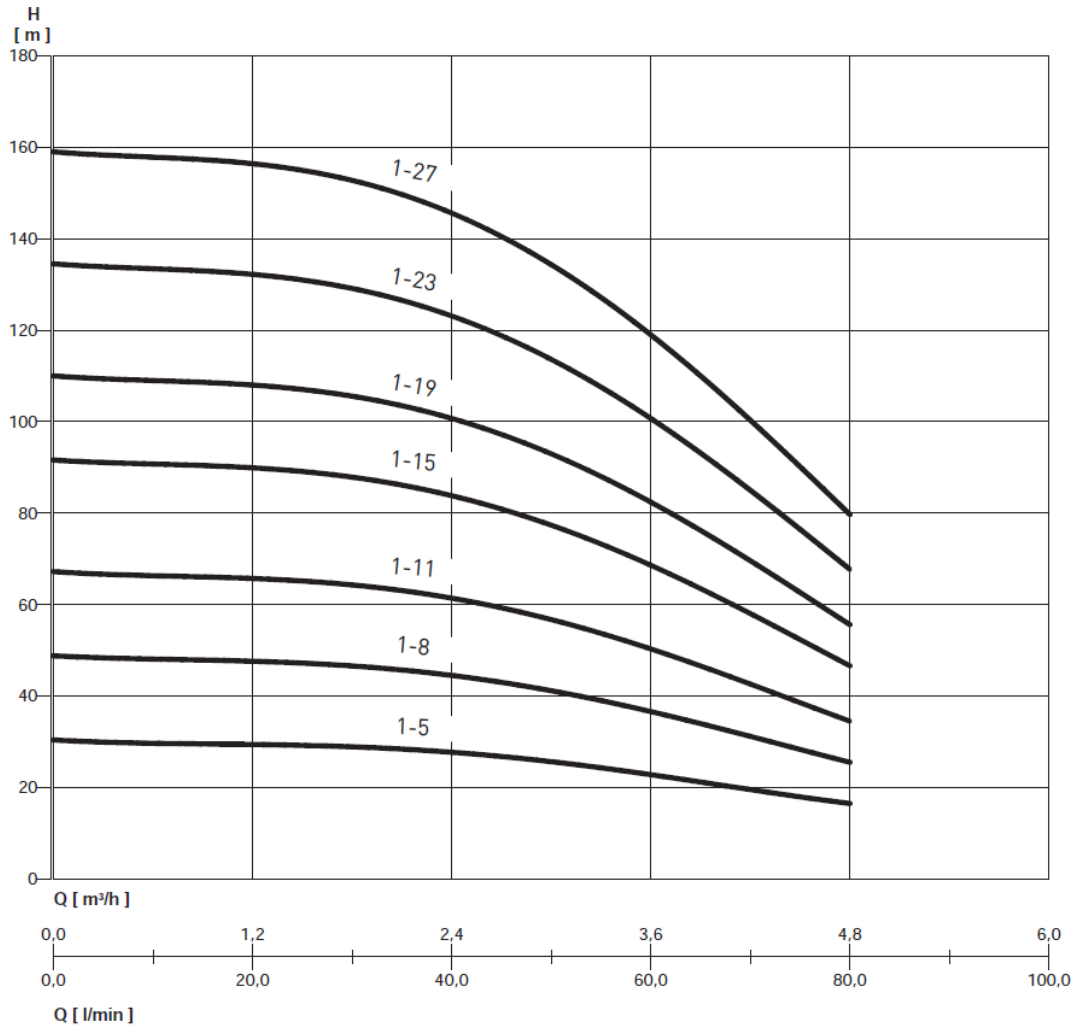

PERFORMANCE TABLE

MODEL	P2	VOLT. (V)	In (A)	Q	l/min	0	20	40	60	80
	kW				m³/h	0	1,2	2,4	3,6	4,8
VARIO3-20 PVM 1-5 F	2x0,37	3 - 400	2x1,5	m.c.w.	30,4	29,4	27,7	22,8	16,5	
VARIO3-20 PVM 1-8 F	2x0,55	3 - 400	2x2,3		48,8	47,6	44,5	36,6	25,5	
VARIO3-20 PVM 1-11 F	2x0,55	3 - 400	2x3,2		67,2	65,7	61,4	50,3	34,5	
VARIO3-20 PVM 1-15 F	2x0,75	3 - 400	2x4,4		91,6	89,9	83,8	68,6	46,6	
VARIO3-20 PVM 1-19 F	2x1,1	3 - 400	2x5,5		110	108	100,7	82,4	55,6	
VARIO3-20 PVM 1-23 F	2x1,1	3 - 400	2x6,7		134,5	132,2	123,1	100,7	67,7	
VARIO3-20 PVM 1-27 F	2x1,5	3 - 400	2x7,8		159	156,4	145,6	119	79,7	

NOCCHI VARIO 3-20 PVM

THREE-PHASE PRESSURE BOOSTER SET WITH TWO VARIABLE SPEED PUMPS

OVERALL DIMENSIONS AND WEIGHTS

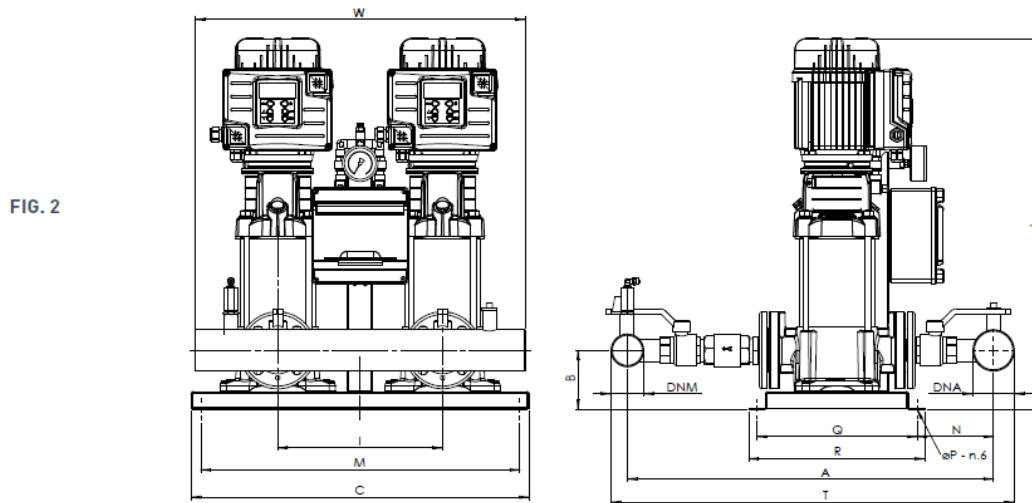
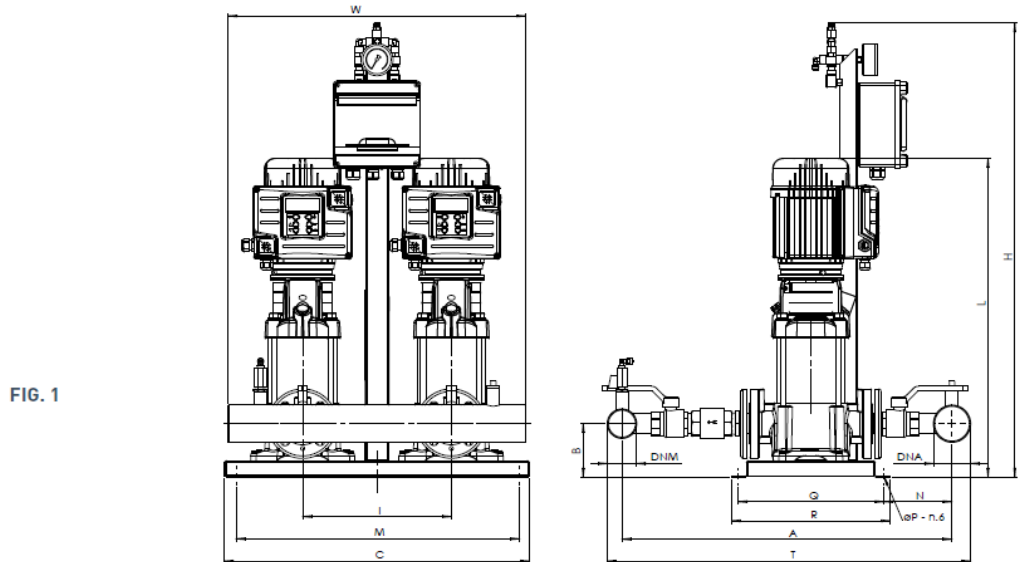

OVERALL DIMENSIONS AND WEIGHTS

MODEL	Fig.	Dimensions mm.														WEIGHT Kg	
		A	B	C	H	I	L	M	N	P	Q	R	T	W	DNA		DNM
VARIO3-20 PVM 1-5 F	1	690	108	615	910	300	543	578,5	145	10,5	290	320	757	600	2"	2"	60
VARIO3-20 PVM 1-8 F	1	690	108	615	910	300	597	578,5	145	10,5	290	320	757	600	2"	2"	62
VARIO3-20 PVM 1-11 F	2	690	108	615	-	300	651	578,5	145	10,5	290	320	757	600	2"	2"	67
VARIO3-20 PVM 1-15 F	2	690	108	615	-	300	769	578,5	145	10,5	290	320	757	600	2"	2"	73
VARIO3-20 PVM 1-19 F	2	690	108	615	-	300	841	578,5	145	10,5	290	320	757	600	2"	2"	80
VARIO3-20 PVM 1-23 F	2	690	108	615	-	300	913	578,5	145	10,5	290	320	757	600	2"	2"	90
VARIO3-20 PVM 1-27 F	2	690	108	615	-	300	1033	578,5	145	10,5	290	320	757	600	2"	2"	94

NOCCHI VARIO 3-20 PVM

THREE-PHASE PRESSURE BOOSTER SET WITH TWO VARIABLE SPEED PUMPS

HYDRAULIC PERFORMANCE

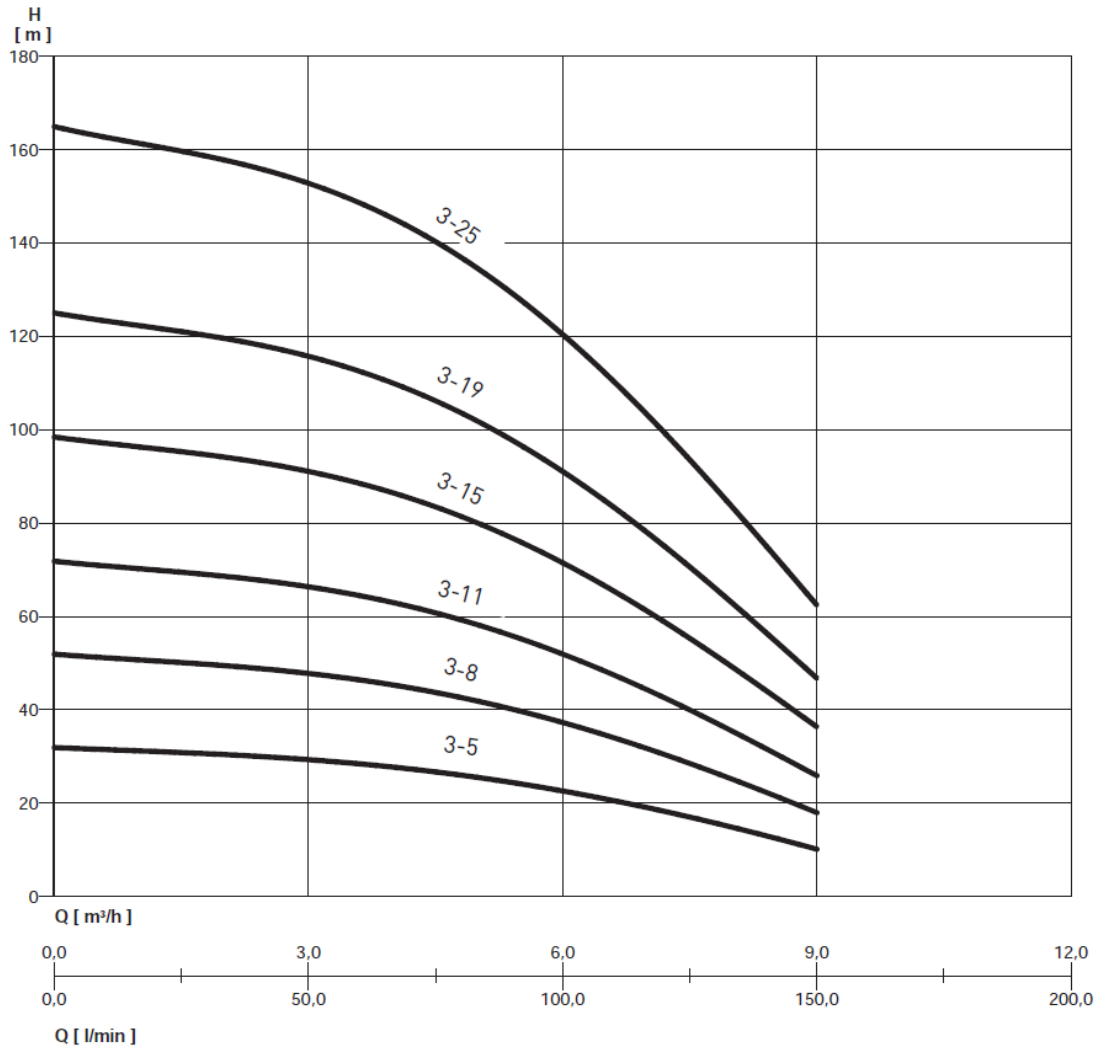

PERFORMANCE TABLE

MODEL	P2	VOLT. (V)	In (A)	Q	l/min	0	20	40	60	80	100	120	140	150
	kW				m³/h	0	1,2	2,4	3,6	4,8	6	7,2	8,4	9
VARIO3-20 PVM 3-5 F	2x0,37	3 - 400	2x0,9	m.c.w.	31,9	31,1	30	28,3	26,2	22,6	18	13,3	10	
VARIO3-20 PVM 3-8 F	2x0,75	3 - 400	2x1,45		51,9	50,5	48,9	46,2	42,9	37,3	30,1	22,7	17,8	
VARIO3-20 PVM 3-11 F	2x1,1	3 - 400	2x2		71,8	70	67,9	64,1	59,6	52,1	42,1	32,1	25,7	
VARIO3-20 PVM 3-15 F	2x1,1	3 - 400	2x2,7		98,4	96	93,2	88	81,9	71,7	58,2	44,7	36,1	
VARIO3-20 PVM 3-19 F	2x1,5	3 - 400	2x3,4		125	121,9	118,4	111,9	104,2	91,3	74,3	57,2	46,5	
VARIO3-20 PVM 3-25 F	2x2,2	3 - 400	2x4,5		164,9	160,8	156,3	147,8	137,6	120,8	98,4	76	62,1	

NOCCHI VARIO 3-20 PVM

THREE-PHASE PRESSURE BOOSTER SET WITH TWO VARIABLE SPEED PUMPS

OVERALL DIMENSIONS AND WEIGHTS

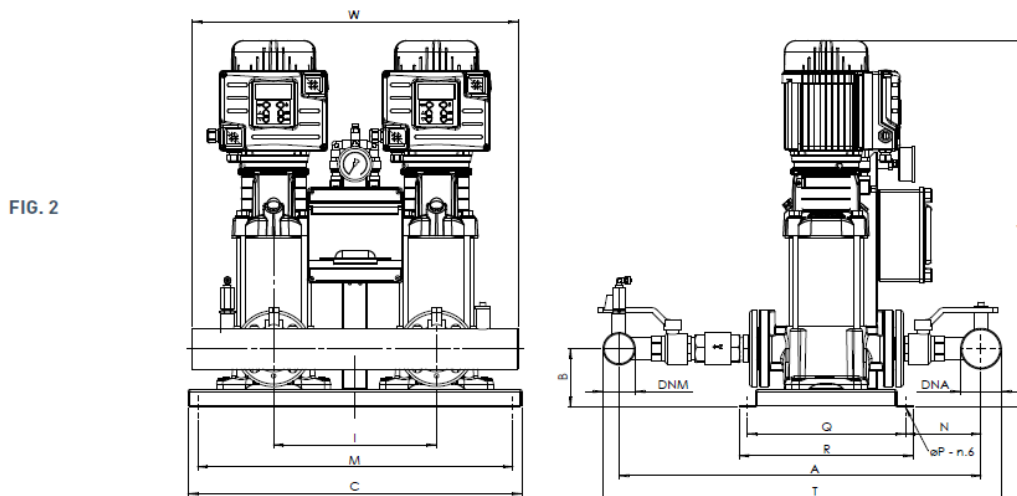
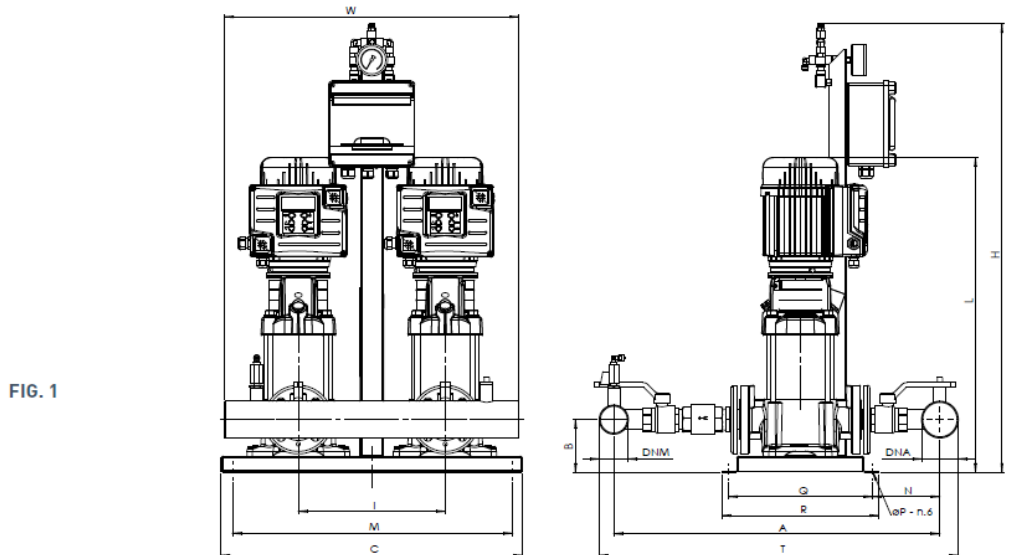

OVERALL DIMENSIONS AND WEIGHTS

MODEL	Fig.	Dimensions mm.													WEIGHT Kg		
		A	B	C	H	I	L	M	N	P	Q	R	T	W		DNA	DNM
VARIO3-20 PVM 3-5 F	1	690	108	615	910	300	543	578,5	145	10,5	290	320	757	600	2"	2"	62
VARIO3-20 PVM 3-8 F	1	690	108	615	910	300	643	578,5	145	10,5	290	320	757	600	2"	2"	65
VARIO3-20 PVM 3-11 F	2	690	108	615	-	300	697	578,5	145	10,5	290	320	757	600	2"	2"	73
VARIO3-20 PVM 3-15 F	2	690	108	615	-	300	769	578,5	145	10,5	290	320	757	600	2"	2"	75
VARIO3-20 PVM 3-19 F	2	690	108	615	-	300	889	578,5	145	10,5	290	320	757	600	2"	2"	80
VARIO3-20 PVM 3-25 F	2	690	108	615	-	300	997	578,5	145	10,5	290	320	757	600	2"	2"	90

NOCCHI VARIO 3-20 PVM

THREE-PHASE PRESSURE BOOSTER SET WITH TWO VARIABLE SPEED PUMPS

HYDRAULIC PERFORMANCE

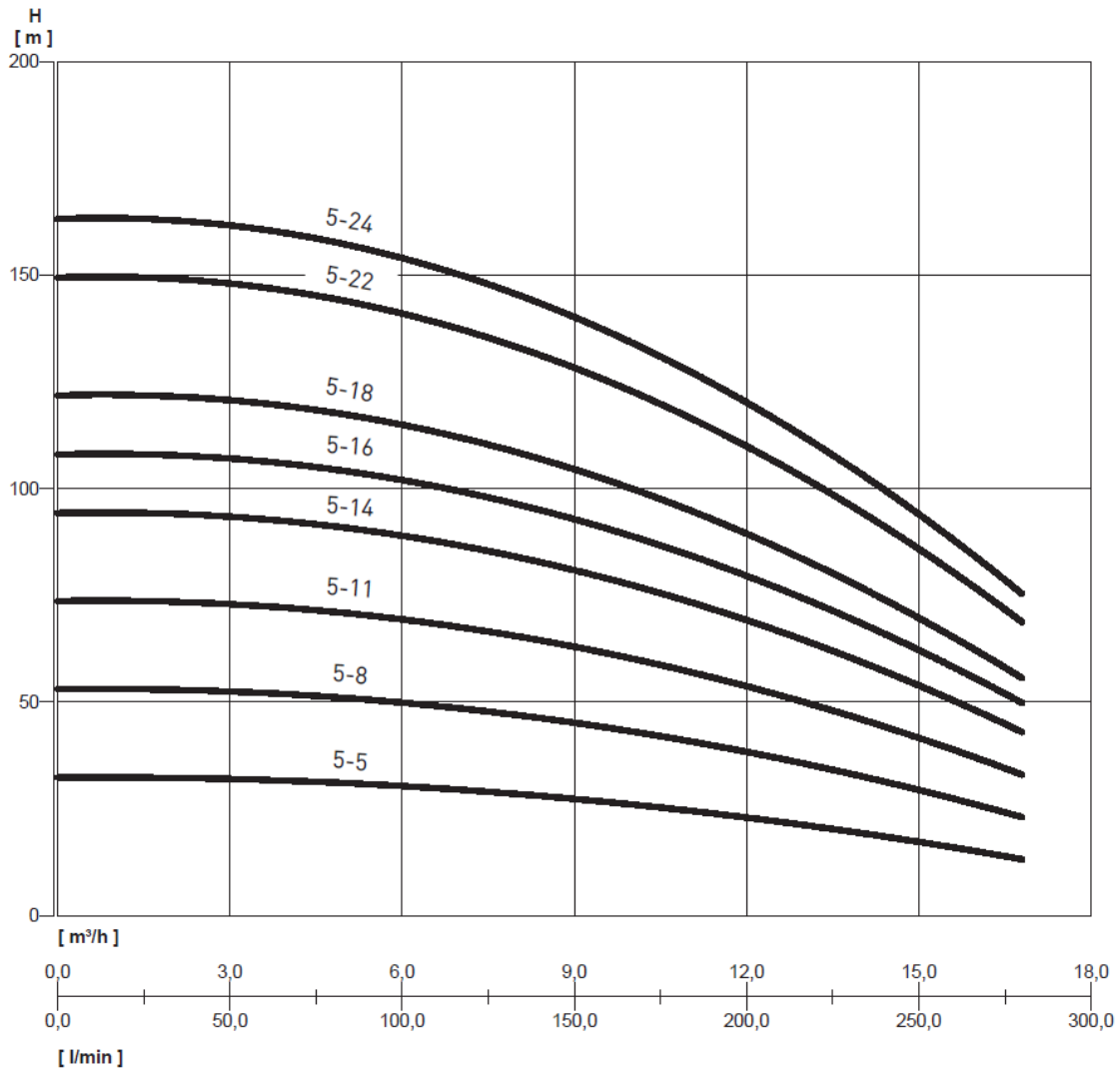

PERFORMANCE TABLE

MODEL	P2	VOLT. (V)	In (A)	Q	U/min	0	80	120	160	200	240	280
	kW				m³/h	0	4,8	7,2	9,6	12	14,4	16,8
VARIO3-20 PVM 5-5 F	2x0,75	3 - 400	2x1,7	m.c.w.		32,3	31,1	29,4	26,8	22,9	18	13,5
VARIO3-20 PVM 5-8 F	2x1,1	3 - 400	2x2,7			52,9	51,1	48,5	44,3	38,2	30,5	23,6
VARIO3-20 PVM 5-11 F	2x2,2	3 - 400	2x3,7			73,5	71,1	67,5	61,8	53,5	43	33,8
VARIO3-20 PVM 5-14 F	2x2,2	3 - 400	2x4,8			94,1	91,1	86,6	79,4	68,9	55,8	43,9
VARIO3-20 PVM 5-16 F	2x2,2	3 - 400	2x5,4			107,8	104,5	99,3	91	79,1	64,7	50,7
VARIO3-20 PVM 5-18 F	2x3	3 - 400	2x6,1			121,5	117,8	112	102,7	89,3	71,1	57,4
VARIO3-20 PVM 5-22 F	2x4	3 - 400	2x7,5			149	144,5	137,4	126,1	109,7	87,6	70,9
VARIO3-20 PVM 5-24 F	2x4	3 - 400	2x8,2			162,7	157,8	150,1	137,8	119,9	95,9	77,7

NOCCHI VARIO 3-20 PVM

THREE-PHASE PRESSURE BOOSTER SET WITH TWO VARIABLE SPEED PUMPS

OVERALL DIMENSIONS AND WEIGHTS

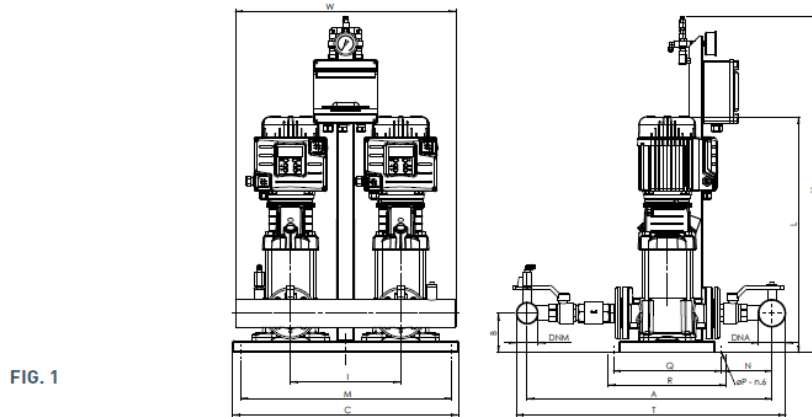

FIG. 1

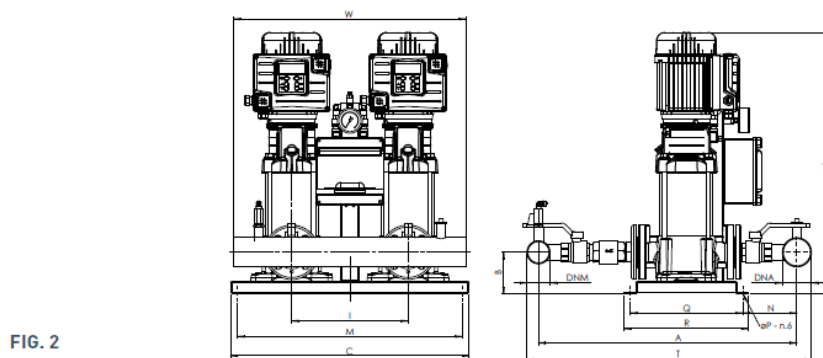

FIG. 2

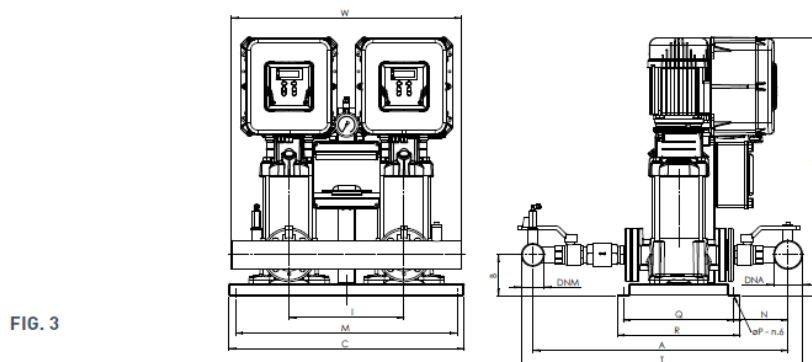

FIG. 3

OVERALL DIMENSIONS AND WEIGHTS

MODEL	Fig.	Dimensions mm.														WEIGHT Kg	
		A	B	C	H	I	L	M	N	P	Q	R	T	W	DNA		DNM
VARIO3-20 PVM 5-5 F	1	690	108	615	910	300	634	578,5	145	10,5	290	320	757	600	2"	2"	76
VARIO3-20 PVM 5-8 F	2	690	108	615	-	300	715	578,5	145	10,5	290	320	757	600	2"	2"	80
VARIO3-20 PVM 5-11 F	2	690	108	615	-	300	844	578,5	145	10,5	290	320	757	600	2"	2"	92
VARIO3-20 PVM 5-14 F	2	690	108	615	-	300	925	578,5	145	10,5	290	320	757	600	2"	2"	98
VARIO3-20 PVM 5-16 F	2	690	108	615	-	300	979	578,5	145	10,5	290	320	757	600	2"	2"	100
VARIO3-20 PVM 5-18 F	3	690	108	615	1091	300	-	578,5	145	10,5	290	320	757	600	2"	2"	142
VARIO3-20 PVM 5-22 F	3	690	108	615	1206	300	-	578,5	145	10,5	290	320	757	600	2"	2"	153
VARIO3-20 PVM 5-24 F	3	690	108	615	1260	300	-	578,5	145	10,5	290	320	757	600	2"	2"	155

NOCCHI VARIO 3-20 PVM

THREE-PHASE PRESSURE BOOSTER SET WITH TWO VARIABLE SPEED PUMPS

HYDRAULIC PERFORMANCE

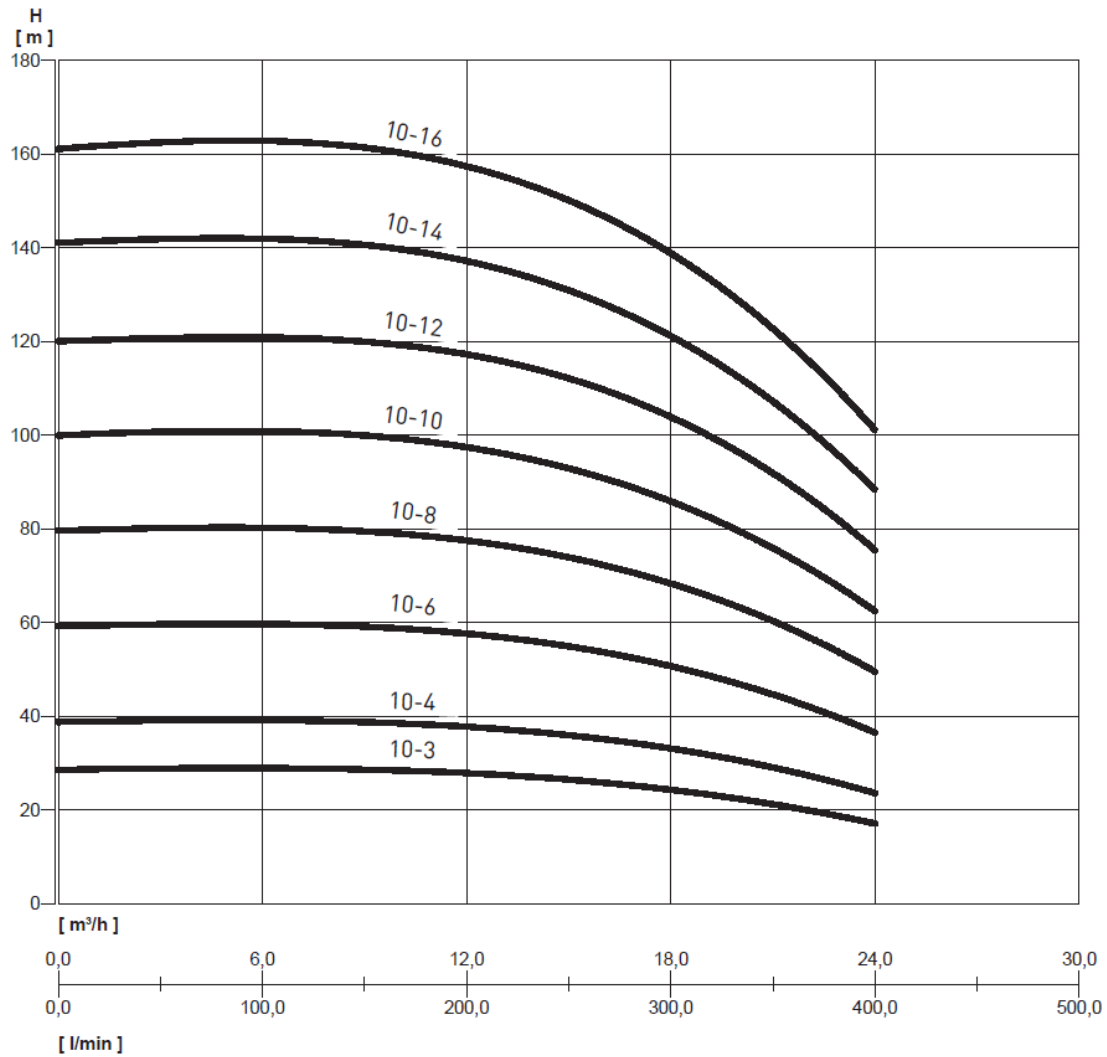

PERFORMANCE TABLE

MODEL	P2	VOLT. (V)	In (A)	Q	U/min	0	100	200	300	400
	kW				m³/h	0	6	12	18	24
VARIO3-20 PVM 10-3 F	2x1,1	3 - 400	2x2,4	m.c.w.		28,6	29	27,8	24,4	17,1
VARIO3-20 PVM 10-4 F	2x1,5	3 - 400	2x3,2			38,8	39,2	37,7	33,2	23,6
VARIO3-20 PVM 10-6 F	2x2,2	3 - 400	2x4,8			59,2	59,8	57,5	50,8	36,5
VARIO3-20 PVM 10-8 F	2x3	3 - 400	2x6,4			79,6	80,3	77,4	68,4	49,5
VARIO3-20 PVM 10-10 F	2x4	3 - 400	2x8			99,9	101	97,2	86	62,4
VARIO3-20 PVM 10-12 F	2x4	3 - 400	2x9,6			120	121	117	104	75,4
VARIO3-20 PVM 10-14 F	2x5,5	3 - 400	2x11			141	142	137	121,2	88,3
VARIO3-20 PVM 10-16 F	2x5,5	3 - 400	2x13			161	163	157	139	101

NOCCHI VARIO 3-20 PVM

THREE-PHASE PRESSURE BOOSTER SET WITH TWO VARIABLE SPEED PUMPS

OVERALL DIMENSIONS AND WEIGHTS

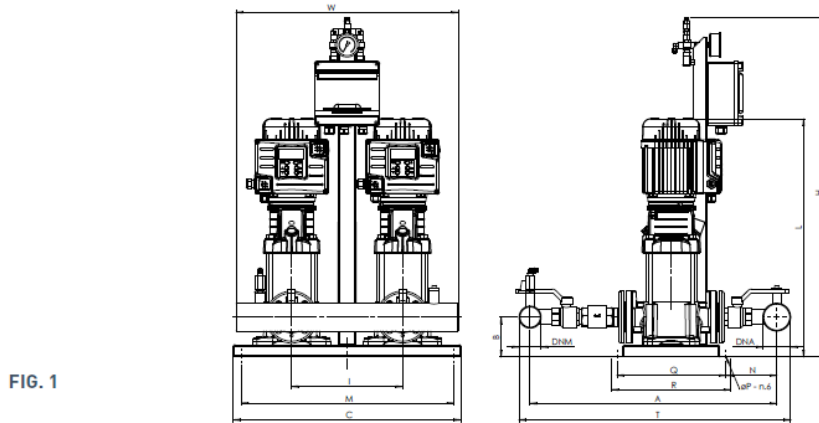

FIG. 1

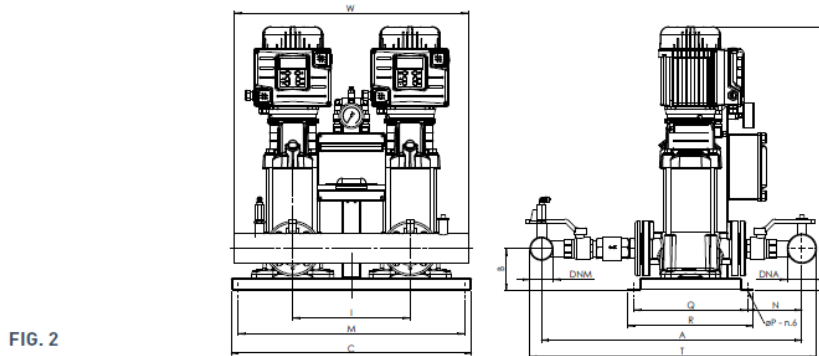

FIG. 2

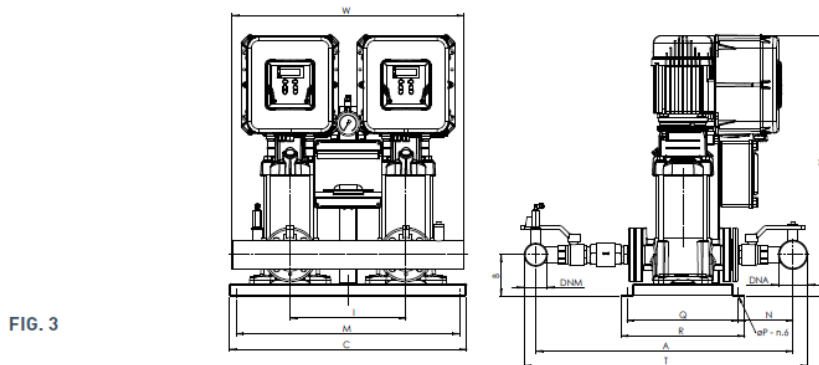

FIG. 3

OVERALL DIMENSIONS AND WEIGHTS

MODEL	Fig.	Dimensions mm.														WEIGHT Kg	
		A	B	C	H	I	L	M	N	P	Q	R	T	W	DNA		DNM
VARI03-20 PVM 10-3 F	1	720	113	620	910	370	645	590	158	10,5	290	320	795	670	2-1/2"	2-1/2"	85
VARI03-20 PVM 10-4 F	2	720	113	620	-	370	723	590	158	10,5	290	320	795	670	2-1/2"	2-1/2"	105
VARI03-20 PVM 10-6 F	2	720	113	620	-	370	783	590	158	10,5	290	320	795	670	2-1/2"	2-1/2"	115
VARI03-20 PVM 10-8 F	3	720	113	620	902	370	-	590	158	10,5	290	320	795	670	2-1/2"	2-1/2"	135
VARI03-20 PVM 10-10 F	3	720	113	620	969	370	-	590	158	10,5	290	320	795	670	2-1/2"	2-1/2"	140
VARI03-20 PVM 10-12 F	3	720	113	620	1029	370	-	590	158	10,5	290	320	795	670	2-1/2"	2-1/2"	145
VARI03-20 PVM 10-14 F	3	720	113	620	1158	370	-	590	158	10,5	290	320	795	670	2-1/2"	2-1/2"	150
VARI03-20 PVM 10-16 F	3	720	113	620	1218	370	-	590	158	10,5	290	320	795	670	2-1/2"	2-1/2"	155

NOCCHI VARIO 3-20 PVM

THREE-PHASE PRESSURE BOOSTER SET WITH TWO VARIABLE SPEED PUMPS

HYDRAULIC PERFORMANCE

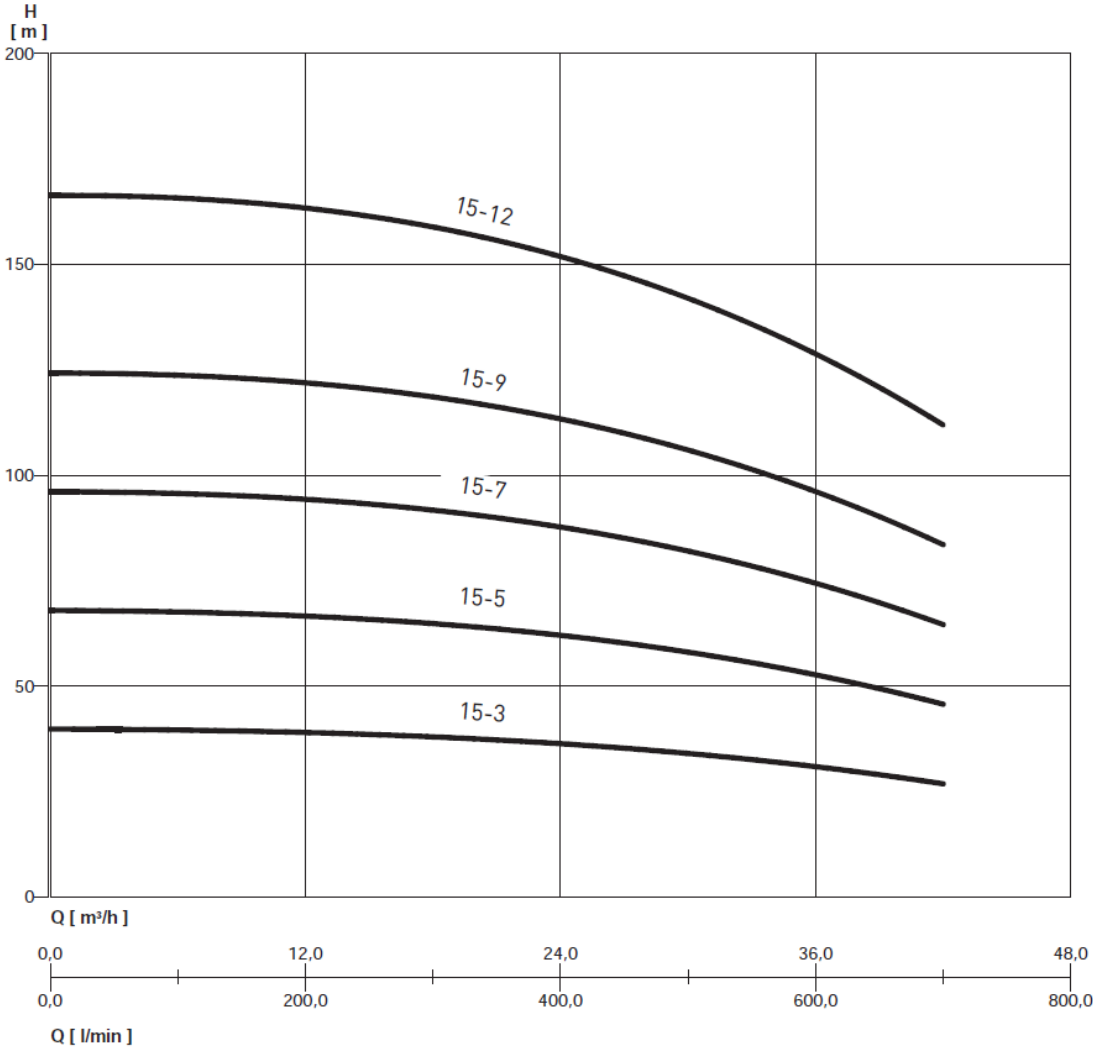

NOCCHI VARIO 3-20 PVM

THREE-PHASE PRESSURE BOOSTER SET WITH TWO VARIABLE SPEED PUMPS

PERFORMANCE TABLE

MODEL	P2	VOLT. (V)	In (A)	Q	U/min	0	100	200	300	400	500	600	700
	kW				m ³ /h	0	6	12	18	24	30	36	42
VARIO3-20 PVM 15-3 F	2x3	3 - 400	2x5,1	m.c.w.		39,8	39,6	39,2	37,8	36,3	34,1	31	26,8
VARIO3-20 PVM 15-5 F	2x4	3 - 400	2x8,5			68	67,4	66,9	64,7	62	58,1	52,7	45,7
VARIO3-20 PVM 15-7 F	2x5,5	3 - 400	2x12			96,2	95,3	94,7	91,6	87,7	82	74,4	64,6
VARIO3-20 PVM 15-9 F	2x7,5	3 - 400	2x15			124,4	123,2	122,4	118,4	113,4	106	96	83,6
VARIO3-20 PVM 15-12 F	2x11	3 - 400	2x20			166,6	165	163,9	158,8	151,9	141,9	128,6	112

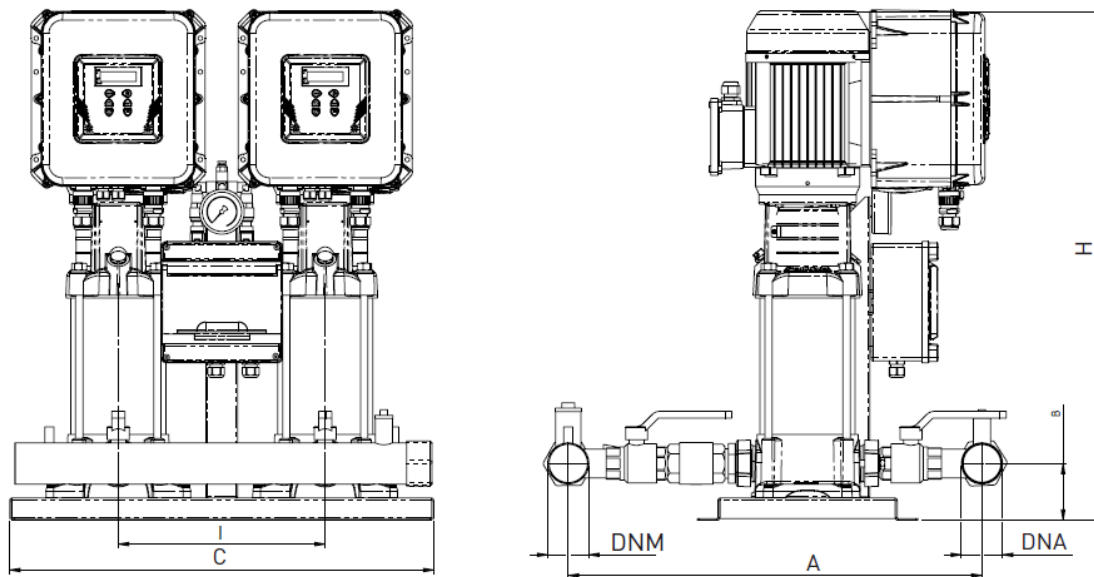

OVERALL DIMENSIONS AND WEIGHTS

MODEL	Dimensions mm.							WEIGHT Kg
	A	B	C	H	I	DNA	DNM	
VARIO3-20 PVM 15-3 F	850	125	710	816	360	3"	3"	140
VARIO3-20 PVM 15-5 F	850	125	710	913	360	3"	3"	160
VARIO3-20 PVM 15-7 F	850	125	710	1072	360	3"	3"	210
VARIO3-20 PVM 15-9 F	850	125	710	1182	360	3"	3"	226
VARIO3-20 PVM 15-12 F	850	125	710	1507	360	3"	3"	250

NOCCHI VARIO 3-20 PVM

THREE-PHASE PRESSURE BOOSTER SET WITH TWO VARIABLE SPEED PUMPS

HYDRAULIC PERFORMANCE

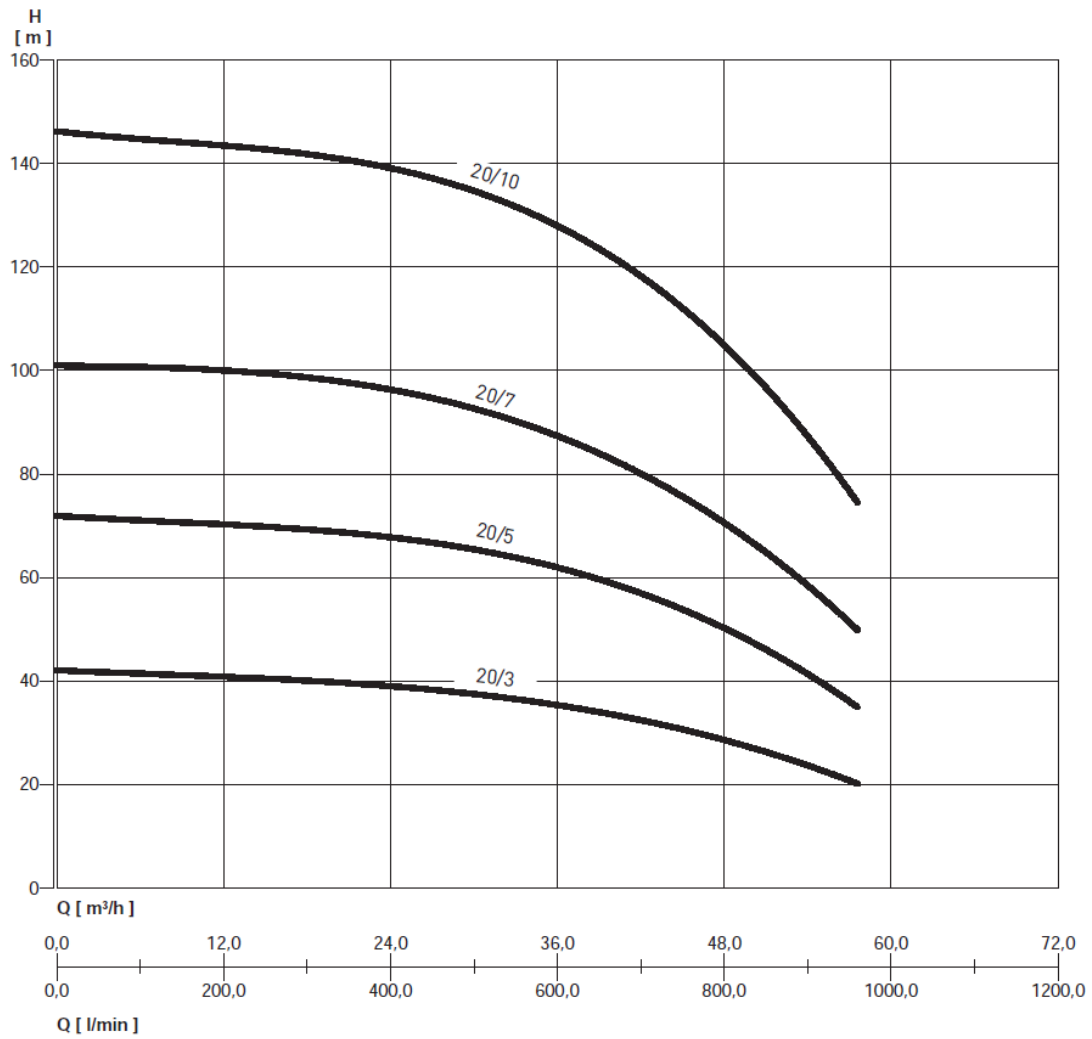

NOCCHI VARIO 3-20 PVM

THREE-PHASE PRESSURE BOOSTER SET WITH TWO VARIABLE SPEED PUMPS

PERFORMANCE TABLE

MODEL	P2	VOLT. (V)	In (A)	Q	U/min	0	200	400	600	800	960
	kW				m ³ /h	0	12	24	36	48	57,6
VARIO3-20 PVM 20-3 F	2x4	3 - 400	2x8,5	m.c.w.	42	41	39	35	29	20	
VARIO3-20 PVM 20-5 F	2x5,5	3 - 400	2x11,9		72	70	68	62	50	35	
VARIO3-20 PVM 20-7 F	2x7,5	3 - 400	2x15,3		101	100	96	88	70	50	
VARIO3-20 PVM 20-10 F	2x11	3 - 400	2x20,4		146	144	139	127	106	74	

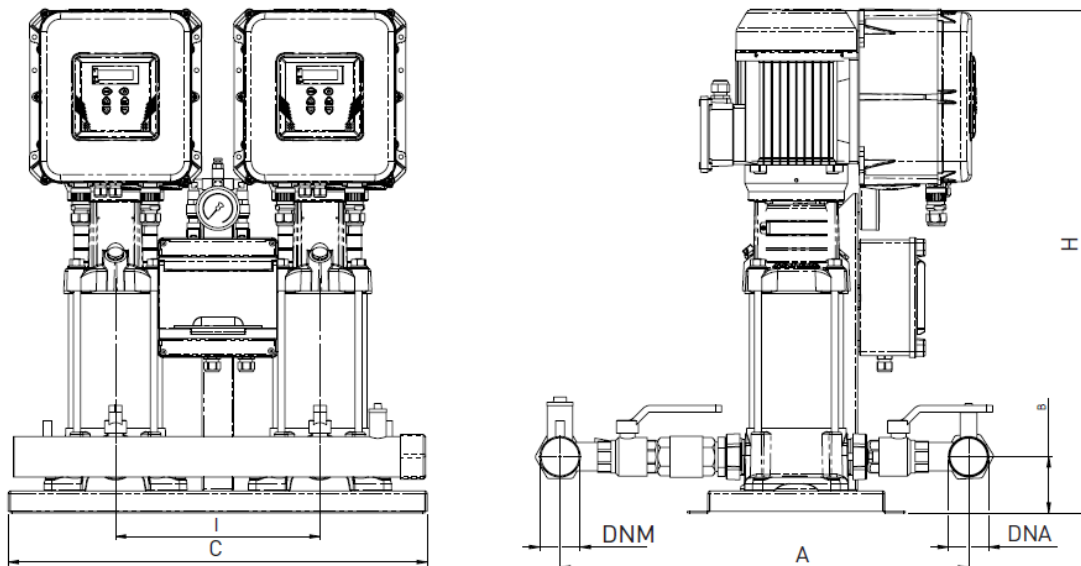

OVERALL DIMENSIONS AND WEIGHTS

MODEL	Dimensions mm.							WEIGHT Kg
	A	B	C	H	I	DNA	DNM	
VARIO3-20 PVM 20-3 F	850	125	710	690	360	3"	3"	140
VARIO3-20 PVM 20-5 F	850	125	710	845	360	3"	3"	160
VARIO3-20 PVM 20-7 F	850	125	710	992	360	3"	3"	180
VARIO3-20 PVM 20-10 F	850	125	710	1122	360	3"	3"	210

NOCCHI VARIO 3-20 PVM

THREE-PHASE PRESSURE BOOSTER SET WITH TWO VARIABLE SPEED PUMPS

HYDRAULIC PERFORMANCE

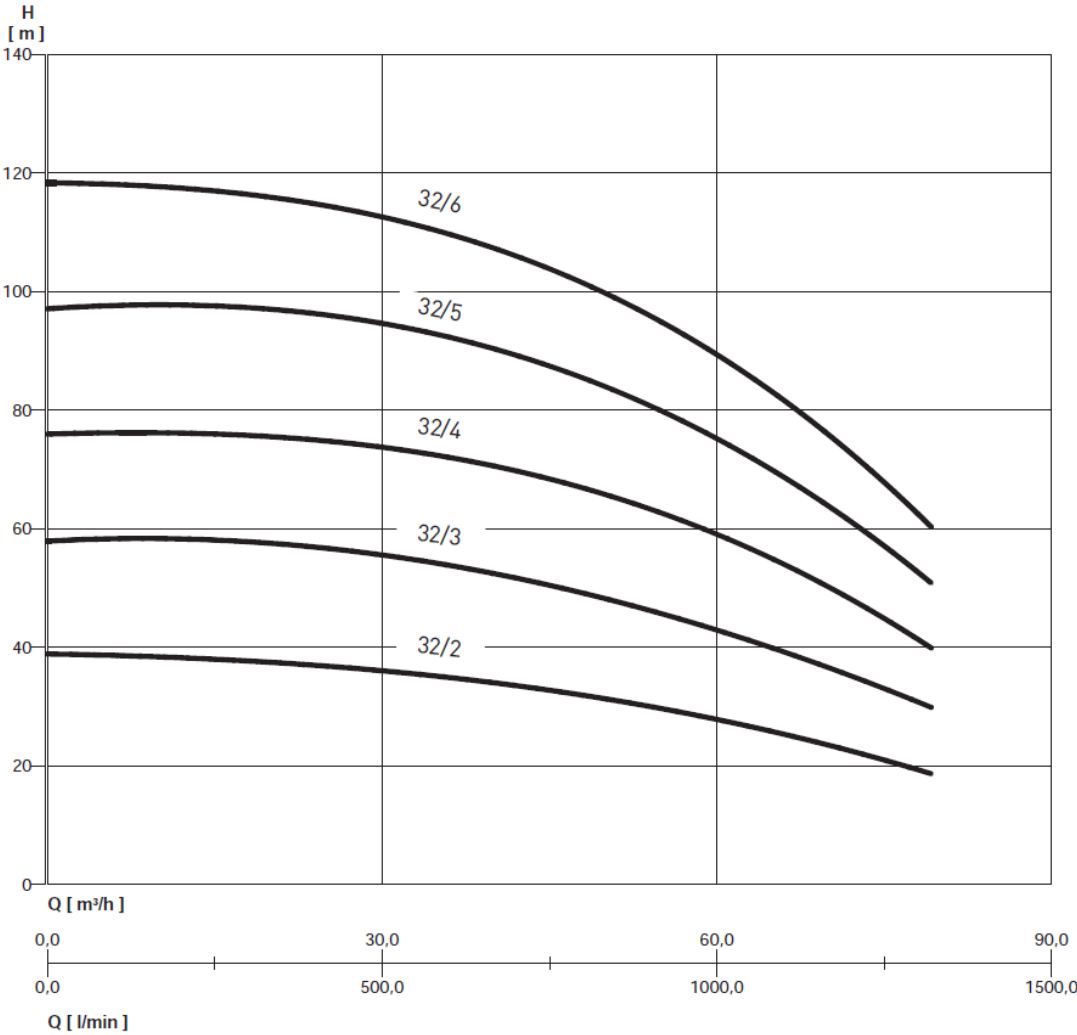

NOCCHI VARIO 3-20 PVM

THREE-PHASE PRESSURE BOOSTER SET WITH TWO VARIABLE SPEED PUMPS

PERFORMANCE TABLE

MODEL	P2	VOLT. (V)	In (A)	Q	U/min	0	12	24	36	48	60	72	79,2
	kW				m ³ /h	0	200	400	600	800	1000	1200	1320
VARIO3-20 PVM 32-2 F	2x4	3 - 400	2x7,1	m.c.w.		39	38	37	35	32	28	22	19
VARIO3-20 PVM 32-3 F	2x5,5	3 - 400	2x10,7			58	58	57	54	49	43	35	30
VARIO3-20 PVM 32-4 F	2x7,5	3 - 400	2x14,3			76	76	75	72	67	59	48	40
VARIO3-20 PVM 32-5 F	2x11	3 - 400	2x17,8			97	98	96	92	86	75	61	51
VARIO3-20 PVM 32-6 F	2x11	3 - 400	2x21,4			118	118	115	109	101	90	73	60

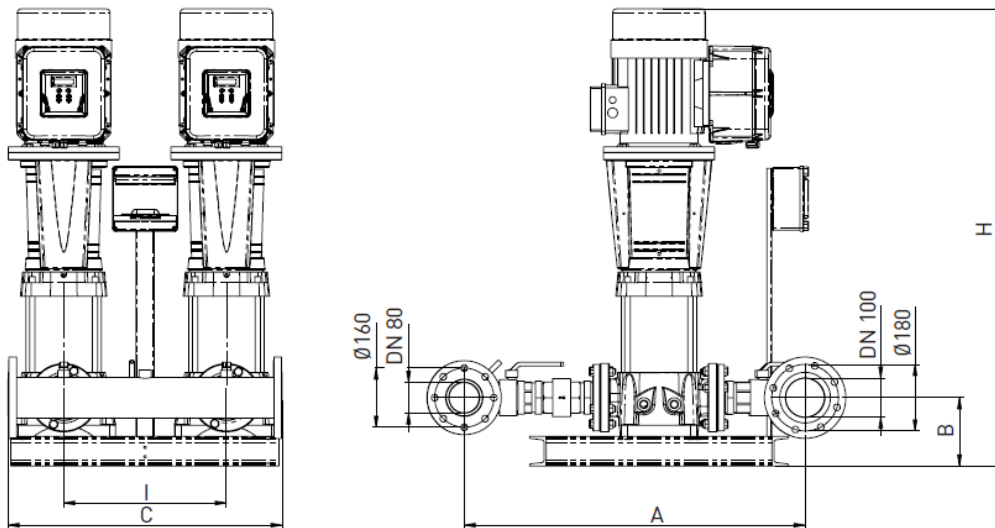

OVERALL DIMENSIONS AND WEIGHTS

MODEL	Dimensions mm.							WEIGHT Kg
	A	B	C	H	I	DNA	DNM	
VARIO3-20 PVM 32-2 F	950	185	750	982	440	4"	3"	300
VARIO3-20 PVM 32-3 F	950	185	750	1089	440	4"	3"	320
VARIO3-20 PVM 32-4 F	950	185	750	1179	440	4"	3"	360
VARIO3-20 PVM 32-5 F	950	185	750	1472	440	4"	3"	380
VARIO3-20 PVM 32-6 F	950	185	750	1542	440	4"	3"	420